

# TRADITIONAL OVEN JOY

## STATIC MONOBLOCK COOKTOP

120

Small yet with the capacity to bake up to 5/6 pizzas, wood fired. It has a MONOBLOCK cooktop and is recommended for restaurants seating a maximum of 40/50 people or for anyone who simply wish to give an extra service to the customers without losing space.

Exceptional performance, compact size, power consumption in line with our traditional ovens, perfect baking for the entire evening. Designed to provide a working tool of the highest standard but still unique, because it is strongly characterized in terms of aesthetics, almost a piece of design.

The cooktop is made in a single refractory block with a thickness of 7 cm and a weight up to 250 kg. All the Pavese gas-fired ovens are supplied with an electronically managed gas burner.

Inside Dimentions	cm	120x115
Weight	Kg.	860
Dome Thickness	cm	8/10
Cook Top - Cover Distance	cm	42
Cook top height from ground	cm	115/125 adjustable
Base Insulation Thickness (Microporous Panels)	cm	10
Dome Insulation Thickness (Kaolin Blanket)	cm	12
Chimney Flue Ø	cm	20
Smokes temperature at the vent		300° - 25 g/sec (50m³/Hr)
Static pressure	Pa	12
Monoblock Cooking Plate		Burner Drago D2
Thermal Potential	Kw	min. 6 - max. 34
Thermal Potential	Kcal/h	min. 5.000 - max. 29.200
Gas Pressure Nat. Gas	mbar	min. 7/20 - max. 25/50
Gas Flow Nat. Gas	Nm³/h	min. 0,63/0,20 max. 3,59/1,22
Gas Coupling	inches	1/2
Weight	kg.	8
Electrical Power Supply	V	230 Single phase
Burner Consumption	W	100

Because Pavese oven is hand made and assembled, slight variations in the measures of the final product are normal

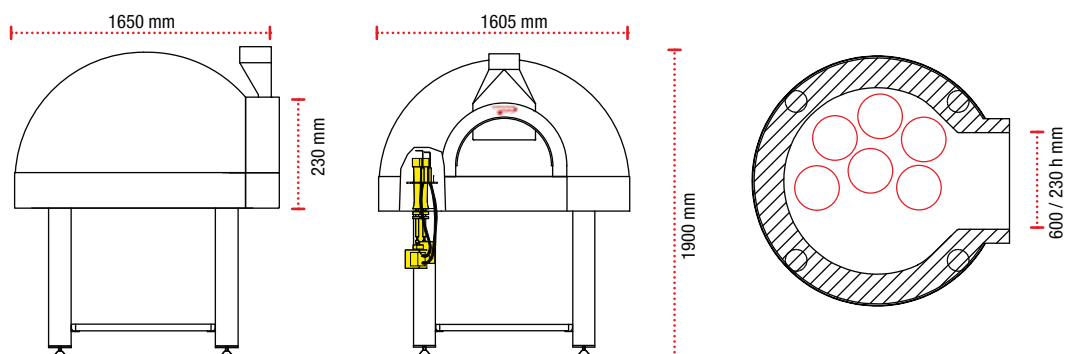

JOY 120



n° 5/6