

TRADITIONAL OVEN JOY 140

STATIC MONOBLOCK COOKTOP

Perfectly circular with a maximum capacity between 7 and 9 pizzas. MONOBLOCK auto-dilating oven. Production capacity of over 100 pizza/ hour. the highest productivity at very low cost.

Exceptional performance, compact size, power consumption in line with our traditional ovens, perfect baking for the entire evening. Designed to provide a working tool of the highest standard but still unique, because it is strongly characterized in terms of aesthetics, almost a piece of design.

The cooktop is made in a single refractory block with a thickness of 7 cm and a weight up to 250 kg.

All the Pavesi gas-fired ovens are supplied with an electronically managed gas burner.

Inside Dimentions	cm	140x135
Weight	Kg.	1320
Dome Thickness	cm	8/10
Cook Top - Cover Distance	cm	42
Cook top height from ground	cm	115/125 adjustable
Base Insulation Thickness (Microporous Panels)	cm	10
Dome Insulation Thickness (Kaolin Blanket)	cm	12
Chimney Flue Ø	cm	20
Smokes temperature at the vent		300° - 25 g/sec (50m³/Hr)
Static pressure	Pa	12
Monoblock Cooking Plate		Burner Drago D2
Thermal Potential	Kw	min. 6 - max. 34
Thermal Potential	Kcal/h	min. 5.000 - max. 29.200
Gas Pressure Nat. Gas	mbar	min. 7/20 - max. 25/50
Gas Flow Nat. Gas	Nm³/h	min. 0,63/0,20 max. 3,59/1,22
Gas Coupling	inches	1/2
Weight	kg.	8
Electrical Power Supply	V	230 Single phase
Burner Consumption	W	100

Because Pavesi oven is hand made and assembled, slight variations in the measures of the final product are normal

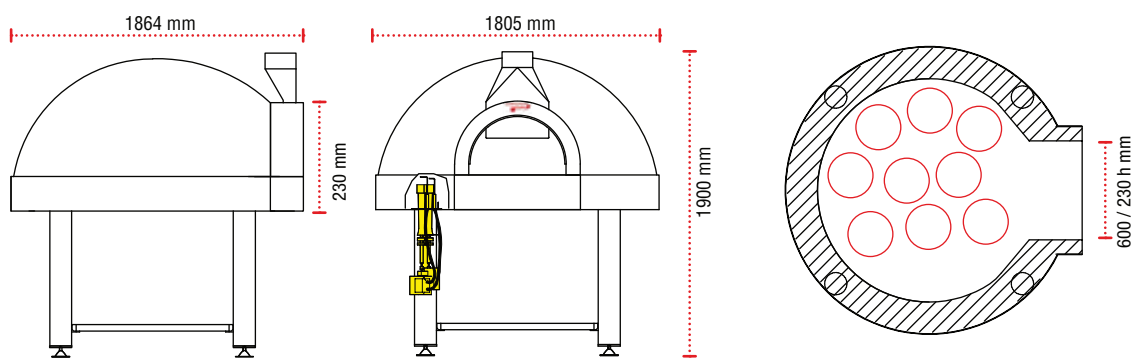

JOY 140



n° 7/9